

Carbide Tipped Dovetail Cutters

Specials in 4-6 Working Days

Machining what part material, please? _____

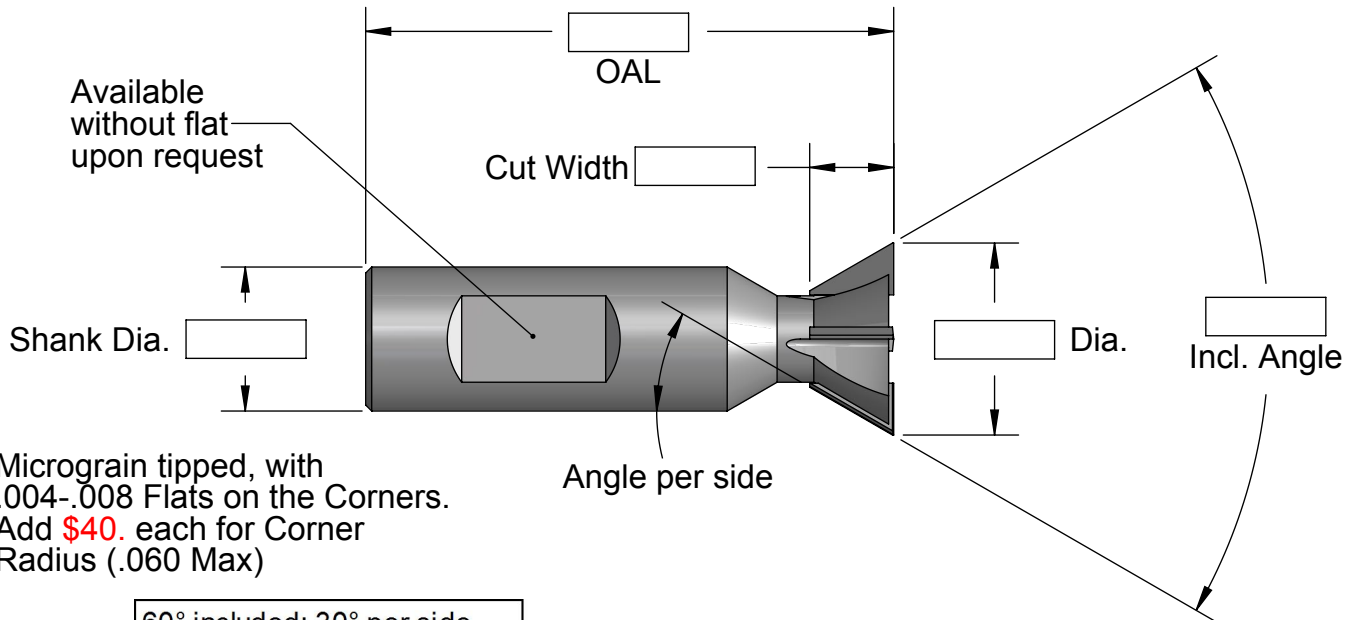

60° included; 30° per side								
Number	Incl. Angle	Dia.	Cut Width	Shank Dia.	OAL	N	Price	
							No-Coat	AlTiN
D60-.75	60°	3/4	5/16	3/4	2-3/4	3	\$180.	\$192.
D60-1.0	60°	1.00	7/16	3/4	2-3/4	4	\$190.	\$206.
D60-1.25	60°	1.25	1/2	3/4	3	5	\$200.	\$220.
D60-1.38	60°	1.38	1/2	3/4	3	6	\$200.	\$223.
D60-1.5	60°	1.50	5/8	3/4	3-1/2	6	\$255.	\$280.
D60-2.0	60°	2.00	7/8	1.0	3-3/4	8	\$290.	\$386.
D60-2.5	60°	2.50	7/8	1.0	3-3/4	8	\$370.	\$482.

90° included; 45° per side								
Number	Incl. Angle	Dia.	Cut Width	Shank Dia.	OAL	N	Price	
							No-Coat	AlTiN
D90-.75	90°	3/4	3/16	1/2	2-1/4	3	\$185.	\$197.
D90-1.0	90°	1.00	1/4	1/2	2-1/2	5	\$195.	\$211.
D90-1.25	90°	1.25	5/16	5/8	2-3/4	5	\$255.	\$275.
D90-1.5	90°	1.50	7/16	3/4	3-1/4	6	\$310.	\$335.
D90-1.75	90°	1.75	1/2	3/4	3-3/4	6	\$350.	\$381.
D90-2.0	90°	2.00	9/16	1.0	4	6	\$380.	\$476.
D90-2.5	90°	2.50	3/4	1.0	4-1/2	6	\$440.	\$552.

N = number of flutes

Phone 916 408-2442 FAX 916 408-0740

Toll free phone 866 440-8665



A. B. TOOLS, INC.
1051 Aviation Blvd.
Lincoln, CA, 95648-9312

If any product is not satisfactory
we will modify, replace or refund.

www.abtoolsinc.com
E-Mail: mail@abtoolsinc.com