

Are you tired of hand ground screw flats on your tool and cutter shanks?

Mill precise flats with our Weldon Flat Tools.

See page 45 for the USCTI Weldon Flat specifications

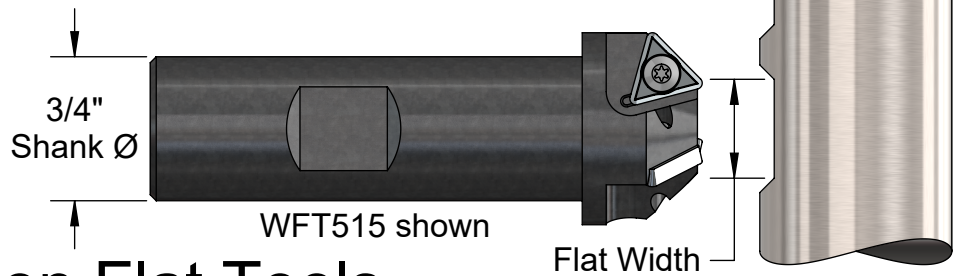

Weldon Flat Tools

Number	Flat Width	For these Shank sizes	Number of Flutes	Price
WFT280	.280	3/8"	1	\$215.
WFT330	.330	1/2"	2	\$235.
WFT400	.400	5/8"	2	\$250.
WFT455	.455	3/4" & 7/8"	3	\$285.
WFT515	.515	1", 1-1/4", 1-1/2"	3	\$310.
WFT700	.700	2"	3	\$375.

We mill Weldon Flats with the WFT515 in 4340 alloy steel hardened to Rc 46 @ 1500 RPM and .002 IPT. These cutters will also mill the shanks on standard HSS end mills which are drawn to Rc 55.

Would you prefer linear flats for easy "Z" Axis adjustment?

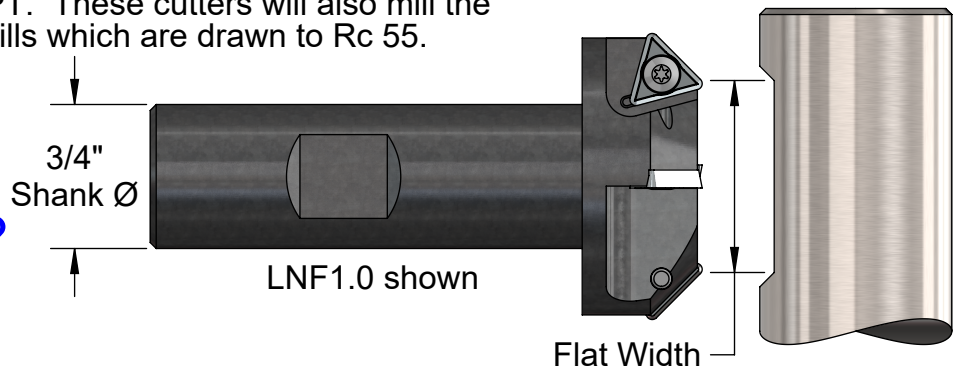

Linear Flat Tools for any Shank size

Number	Flat Width	Number of Flutes	Price
LNF750	.750	4	\$385.
LNF1.0	1.000	4	\$410.
LNF1125	1.125	4	\$440.
LNF1250	1.250	5	\$495.

Insert	Price
TPMT2-2	\$17.50

Screw	Price
SR 14-505	\$5.00

Wrench	Price
T-7	\$7.50



A. B. TOOLS, INC.
1051 Aviation Blvd.
Lincoln, CA 95648-9312

Phone 916 408-2442
FAX 916 993-3949

www.abtoolsinc.com
E-Mail: mail@abtoolsinc.com