

# Spot-Dex Tools (for all part materials)

SD-90T3 shown here

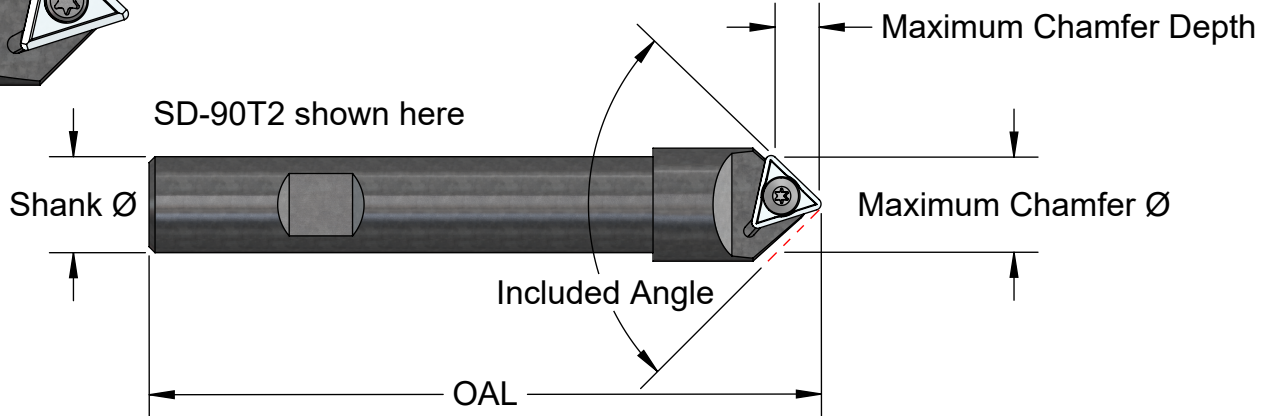

SD-60D3 shown here

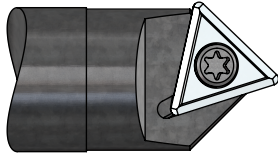
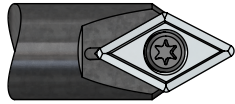

SD-60D2 shown here

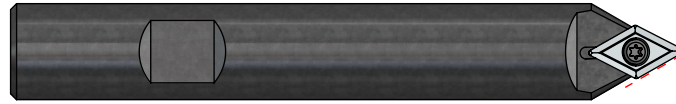

60° Included

\*These all use Industry Standard inserts with secondary clearance facets ground to avoid dragging on the small cut diameters.\*

We've spot drilled to .190 depth with the SD-60D2 in mild steel at 4000 RPM and 1 IPM, and milled grooves in X-Y at 10 IPM.

Number	Included Angle	Max Chamfer Ø	Max Chamfer Depth	*Insert No. (modified)	Screw Size	Shank Ø & OAL	Price including Wrench & Screw
SD-60D2	60°	.310	.240	DPMT-21.51	2.5MM	1/2" X 3.5	\$200.
SD-60D3	60°	.480	.380	DPMT-32.52	4MM		\$220.
SD-70D2	70°	.350	.230	DPMT-21.51	2.5MM		\$200.
SD-70D3	70°	.530	.340	DPMT-32.52	4MM		\$220.
SD-82T2	82°	.530	.290	TPMT2-2	4-40	1/2" X 3.5	\$200.
SD-82T3	82°	.770	.410	TPMT322	4MM	3/4" X 5.0	\$220.
SD-90T2	90°	.570	.270	TPMT2-2	4-40	1/2" X 3.5	\$200.
SD-90T3	90°	.820	.390	TPMT322	4MM	3/4" X 5.0	\$220.
SD-100T2	100°	.610	.240	TPMT2-2	4-40	1/2" X 3.5	\$200.
SD-100T3	100°	.890	.350	TPMT322	4MM	3/4" X 5.0	\$220.
SD-120T2	120°	.680	.190	TPMT2-2	4-40	1/2" X 3.5	\$200.
SD-120T3	120°	.990	.270	TPMT322	4MM	3/4" X 5.0	\$220.

Insert Number	R. Size	Price
DPMT-21.51	.015	\$17.50
TPMT2-2	.031	\$16.00
DPMT-32.52	.031	\$19.00
TPMT322	.031	\$19.00

Screw	Price
2.5 MM	\$4.25
4-40	\$5.00
4 MM	\$5.00
4 MM	\$5.00

Wrench	Price
T-7	\$7.50
T-7	\$7.50
T-15	\$10.00
T-15	\$10.00



A. B. TOOLS, INC.  
1051 Aviation Blvd.  
Lincoln, CA 95648-9312

Phone 916 408-2442  
FAX 916 993-3949

www.abtoolsinc.com  
E-Mail: mail@abtoolsinc.com