

Solid Carbide Slot & Chamfer Picatinny Rail End Mill

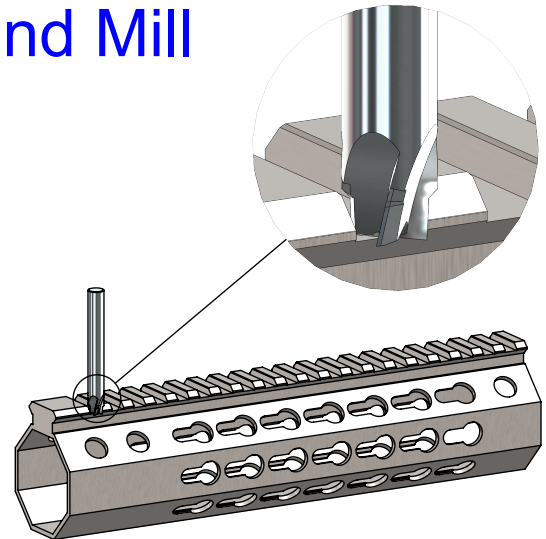
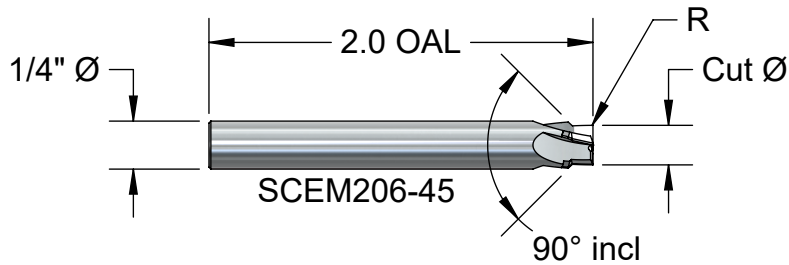

Number	Cut Ø	Radius	Price			AITIN add
			3 flutes	4 flutes	5 flutes	
SCEM206-45	.206	None	\$60.	\$70.	\$81.	\$4.
SCEM206-45-10R	.206	.010	\$70.	\$81.	\$91.	\$4.
SCEM206-45-20R	.206	.020	\$70.	\$81.	\$91.	\$4.
SCEM210-45	.210	None	\$60.	\$70.	\$81.	\$4.
SCEM210-45-10R	.210	.010	\$70.	\$81.	\$91.	\$4.
SCEM210-45-20R	.210	.020	\$70.	\$81.	\$91.	\$4.

Special Slot & Chamfer End Mills in 4-6 Working Days

Machining what part material, please? _____

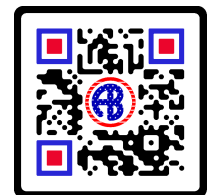
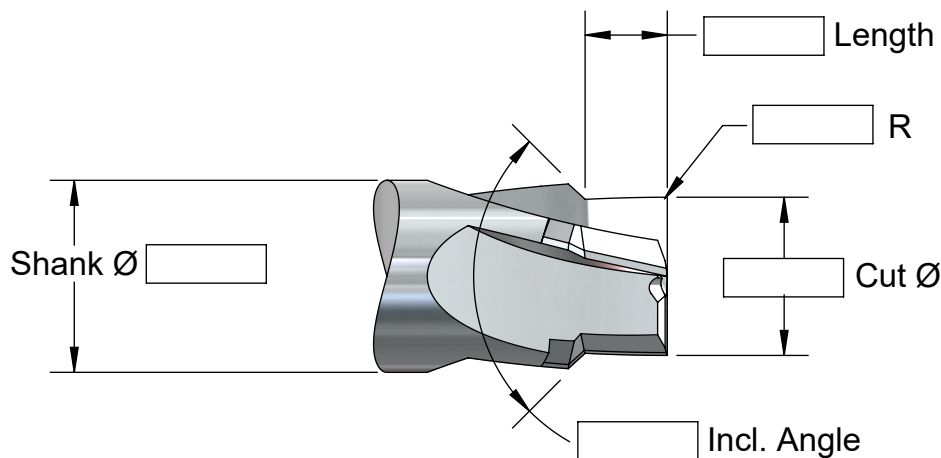

Request For Quote



A. B. TOOLS, INC.
1051 Aviation Blvd.
Lincoln, CA 95648-9312

Phone 916 408-2442
FAX 916 993-3949

www.abtoolsinc.com
E-Mail: mail@abtoolsinc.com