

Solid Carbide Chamfer End Mills

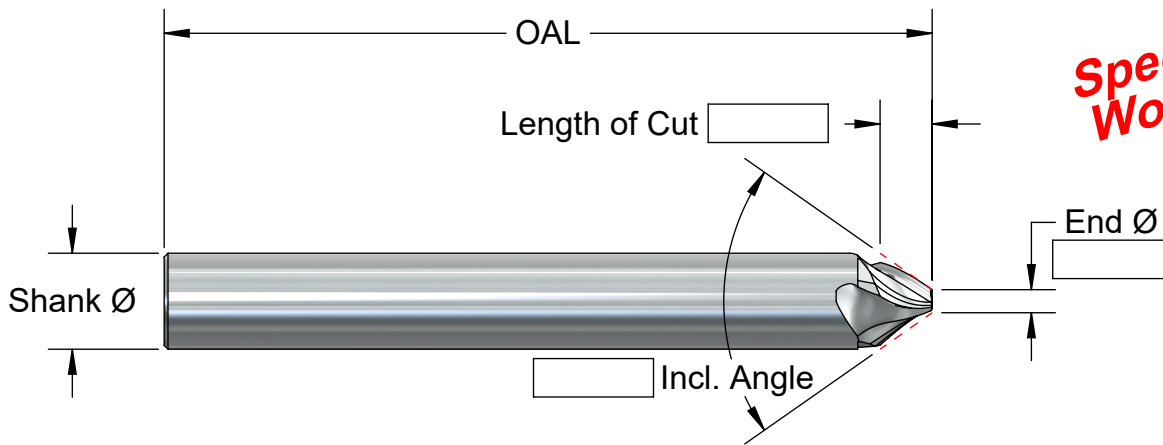

Specials in 4-6 Working Days



Request For Quote

Number	End Ø	Incl. Angle	Length of Cut	Shank Ø X OAL	No. of Flutes	Price	
						No-Coat	AlTiN
CEM060-70	.060	70°	.136	1/4" X 2.0	3	\$80.	\$84.
CEM060-74	.060	74°	.126	1/4" X 2.0	3	\$80.	\$84.
CEM060-80	.060	80°	.113	1/4" X 2.0	3	\$80.	\$84.
CEM060-82	.060	82°	.109	1/4" X 2.0	3	\$80.	\$84.
CEM060-90	.060	90°	.095	1/4" X 2.0	3	\$80.	\$84.
CEM060-100	.060	100°	.080	1/4" X 2.0	3	\$80.	\$84.
CEM060-120	.060	120°	.091	3/8" X 2.5	3	\$95.	\$102.
CEM120-70	.120	70°	.182	3/8" X 2.5	3	\$95.	\$102.
CEM120-74	.120	74°	.169	3/8" X 2.5	3	\$95.	\$102.
CEM120-80	.120	80°	.152	3/8" X 2.5	3	\$95.	\$102.
CEM120-82	.120	82°	.147	3/8" X 2.5	3	\$95.	\$102.
CEM120-90	.120	90°	.128	3/8" X 2.5	3	\$95.	\$102.
CEM120-100	.120	100°	.107	3/8" X 2.5	3	\$95.	\$102.
CEM120-120	.120	120°	.110	1/2" X 2.5	3	\$110.	\$119.
CEM180-70	.180	70°	.229	1/2" X 2.5	3	\$110.	\$119.
CEM180-74	.180	74°	.212	1/2" X 2.5	3	\$110.	\$119.
CEM180-80	.180	80°	.191	1/2" X 2.5	3	\$110.	\$119.
CEM180-82	.180	82°	.184	1/2" X 2.5	3	\$110.	\$119.
CEM180-90	.180	90°	.160	1/2" X 2.5	3	\$110.	\$119.
CEM180-100	.180	100°	.134	1/2" X 2.5	3	\$110.	\$119.
CEM180-120	.180	120°	.128	5/8" X 3.0	3	\$130.	\$142.

These are stocked with helical flutes. Positive axial rake is an option, same price. Ask for the same tool with -AX at the end of the tool number. eg: CEM120-90-AX



A. B. TOOLS, INC.
1051 Aviation Blvd.
Lincoln, CA 95648-9312

Phone 916 408-2442
FAX 916 993-3949

www.abtoolsinc.com
E-Mail: mail@abtoolsinc.com