

# Solid Carbide Bevel Cutters

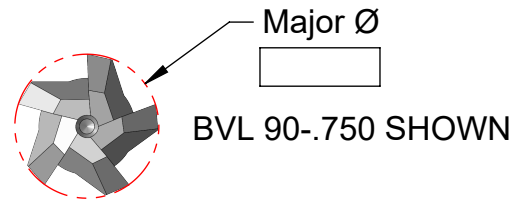
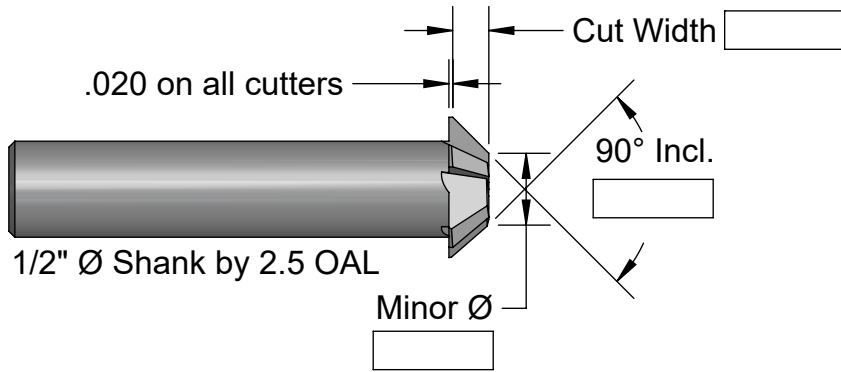

Request For Quote

**Specials in 4-6 Working Days**

## 90° Included Angles

Number	Major Ø	Minor Ø	Cut Width	Number of Flutes	Price
BVL 90-.500	.500	.250	.125	4	<b>\$125.</b>
BVL 90-.750	.750	.375	.188	5	<b>\$150.</b>
BVL 90-1.00	1.000	.375	.312	6	<b>\$185.</b>
BVL 90-1.25	1.250	.500	.375	8	<b>\$220.</b>
BVL 90-1.50*	1.500	.500	.500	10	<b>\$265.</b>

## 60° Included Angles

Number	Major Ø	Minor Ø	Cut Width	Number of Flutes	Price
BVL 60-.500	.500	.246	.220	4	<b>\$125.</b>
BVL 60-.750	.750	.390	.312	5	<b>\$150.</b>
BVL 60-1.00	1.000	.503	.430	6	<b>\$185.</b>
BVL 60-1.25*	1.250	.673	.500	8	<b>\$225.</b>
BVL 60-1.50*	1.500	.778	.625	10	<b>\$275.</b>

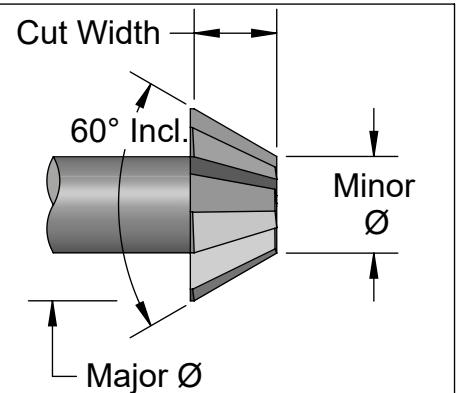

## 120° Included Angles

Number	Major Ø	Minor Ø	Cut Width	Number of Flutes	Price
BVL 120-.500	.500	.188	.090	4	<b>\$125.</b>
BVL 120-.750	.750	.317	.125	5	<b>\$150.</b>
BVL 120-1.00	1.000	.350	.188	6	<b>\$185.</b>
BVL 120-1.25	1.250	.488	.220	8	<b>\$220.</b>
BVL 120-1.50	1.500	.634	.250	10	<b>\$265.</b>

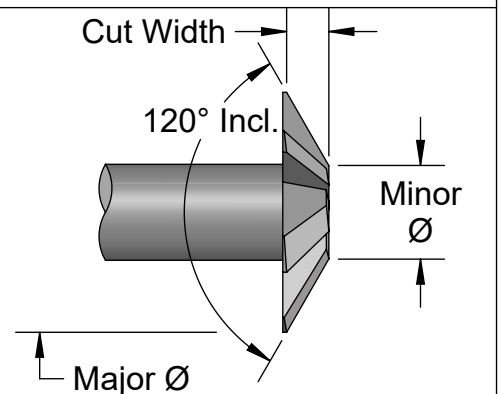

\* These cutters are on 3/4" Ø shank and 2.75 OAL



A. B. TOOLS, INC.  
1051 Aviation Blvd.  
Lincoln, CA 95648-9312

Phone 916 408-2442  
FAX 916 993-3949

www.abtoolsinc.com  
E-Mail: mail@abtoolsinc.com