

Solid Carbide Corner Rounders

CNC Profile Ground, Double End



Request For Quote

The Major Cut \varnothing equals
the Minor $\varnothing + (R. \times 2) + .020$

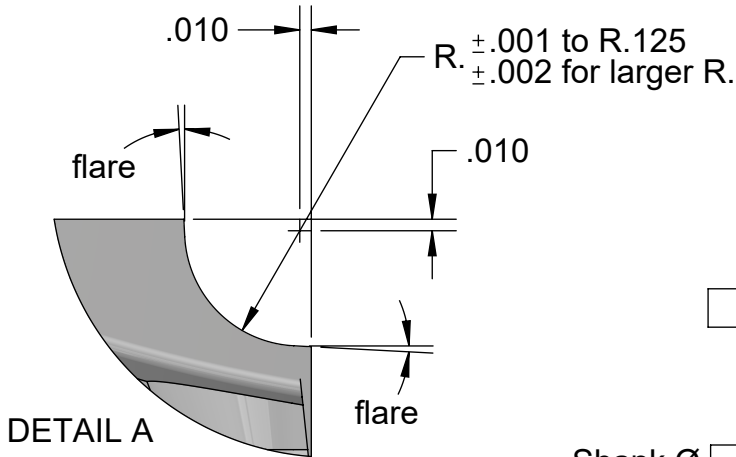
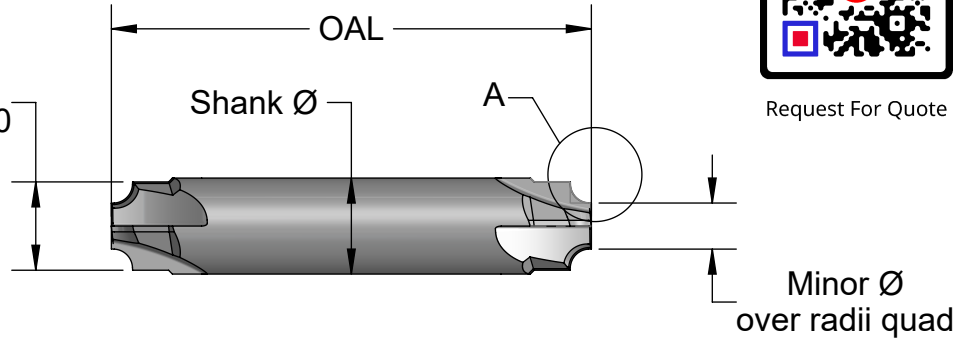

**Special Corner Rounders
in 4-6 working days**

**Machining what part
material, please?**

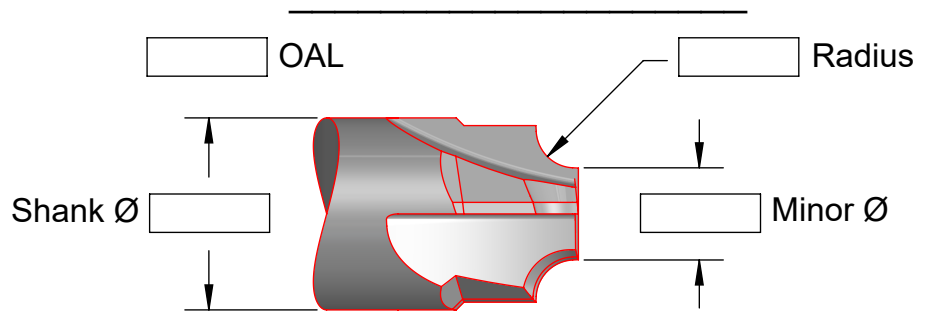

All AB Tools corner rounders
are made with these features
to avoid gouging.

Tool No.	(add R. to prefix, example CR12-031) Radius Sizes Available	Minor \varnothing	No. Flutes	Shank \varnothing & OAL	Prices	
					No-Coat	AlTiN
CR1-____	.010 .013 .015 .018 .020 .022 .025 .028 .031 .035 .038 .040 .046 .048 .050 .055	.240	4	3/8" x 2.5	\$100.	\$114.
CR2-____	.062 .070 .078 .080 .085 .093 .100 .109 .118 .120 .125			1/2" x 2.5	\$125.	\$143.
	.140 .156 .170 .187			5/8" x 3.5	\$195.	\$221.
	.197 .203 .218 .234 .250			3/4" x 4.0	\$230.	\$260.
CR03-____	.010 .015 .020 .025 .031 .040 .046 .050 .055 .062 .070 .078	.030	2	3/16" x 2.0	\$65.	\$72.
CR06-____	.010 .013 .015 .018 .020 .022 .025 .028 .031 .035 .040 .046 .048 .050 .055 .060	.060	2	3/16" x 2.0	\$65.	\$72.
CR12-____	.010 .013 .015 .018 .020 .022 .025 .028 .031 .035 .038 .040 .046 .048 .050 .055 .060	.120	2	1/4" x 2.0	\$75.	\$83.
CR18-____	.015 .020 .031 .035 .046 .055 .062 .070 .078 .080 .085 .093 .098 .109 .118 .120 .125 .130 .135 .140 .150 .156	.180	3	3/8" x 2.5	\$100.	\$114.
	.170 .180 .1875 .197 .203 .218			1/2" x 2.5	\$125.	\$143.
	.234 .250			5/8" x 3.5	\$195.	\$221.
				3/4" x 4.0	\$230.	\$260.



A. B. TOOLS, INC.
1051 Aviation Blvd.
Lincoln, CA 95648-9312

Phone 916 408-2442
FAX 916 993-3949

www.abtoolsinc.com
E-Mail: mail@abtoolsinc.com