

SAW ARBORS for Carbide or HSS Saws with key drives for 5/8 and larger arbors

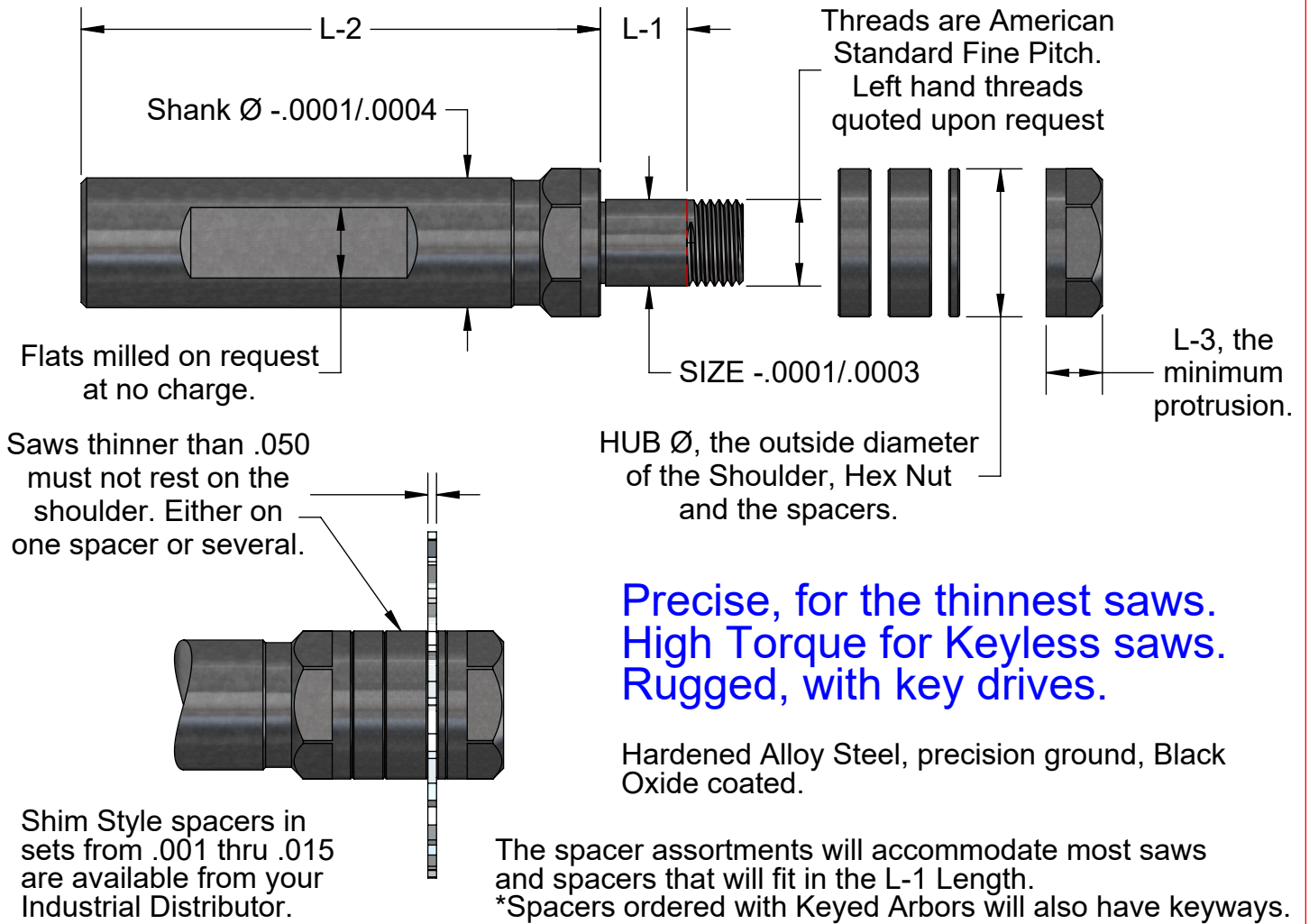

Number	Size	Shank Ø	L-1	L-2	L-3	Hub Ø	Spacers with each Arbor	Price
SA250	.250	1/2"	.350	2.13	.250	.570	.0625 .125 .1875	\$235.
SA375	.375	5/8"	.375	2.40	.280	.710		\$255.
SA500	.500	3/4"	.500	3.00	.325	.855		\$275.
SA625	.625	7/8"	.500	3.15	.390	1.000	.0625 .1875 .250	\$350.
SA750	.750	1"	.500	3.40	.440	1.215		\$365.
SA875	.875	1"	.500	3.40	.440	1.434		\$380.
SA100	1.00	1"	.500	3.50	.440	1.480		\$420.
SA125	1.25	1-1/4"	.500	3.50	.440	2.000		\$510.

*Sorry, unable to manufacture precise spacers thinner than .0625 in steel; suggest Robb-Jack's Solid Carbide spacers for thinner sizes.



A. B. TOOLS, INC.
1051 Aviation Blvd.
Lincoln, CA 95648-9312

Phone 916 408-2442
FAX 916 993-3949

www.abtoolsinc.com
E-Mail: mail@abtoolsinc.com