

NEW !!! Thru-Coolant Saw Arbors

NEW !!!

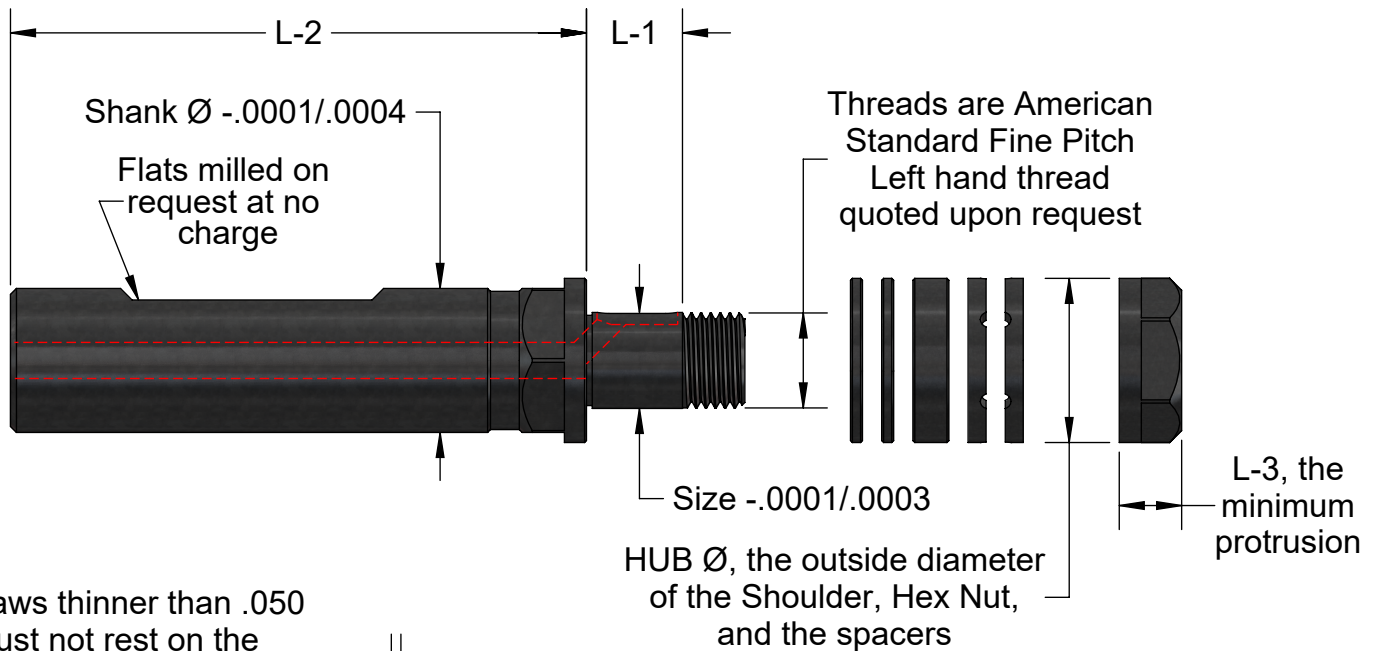

Saws thinner than .050 must not rest on the shoulder. Either on one spacer or several

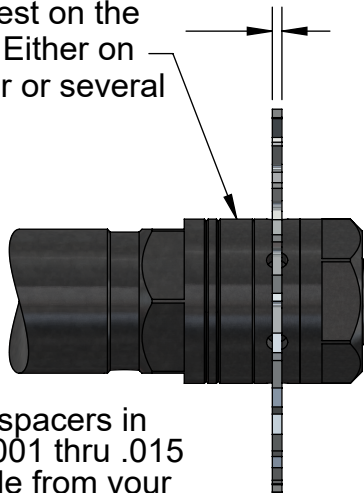

Shim style spacers in sets from .001 thru .015 are available from your Industrial Distributor

Precise, for the thinnest saws.
 High Torque for Keyless saws.
 Rugged, with key drives.



Hardened Alloy Steel, precision ground, Black Oxide coated.

The spacer assortment will accommodate most saws and spacers that will fit in the L-1 length. Spacers ordered with Keyed Arbors will also have keyways.

Replacement Outer Flange Sets	
Number	Price
TCOF375	\$100.00
TCOF500	\$100.00
TCOF625	\$100.00
TCOF750	\$100.00
TCOF875	\$100.00
TCOF100	\$125.00
TCOF125	\$125.00

For spacers thinner than .0625 or thru-Coolant for Gang saw applications we suggest RobbJack's Solid Carbide spacers.

Number	Size	Shank Ø	L-1	L-2	L-3	Hub Ø	Spacers with each Arbor	Thru-Coolant Outer Flange	Price
SATC375*	.375	5/8"	.375	2.40	.280	.710	3pcs - .0625	2pcs - .0937	\$469.00
SATC500*	.500	3/4"	.500	3.00	.325	.855	2pcs - .0625, 1 pc - .1875		\$550.00
SATC625	.625	7/8"	.500	3.15	.390	1.000			\$700.00
SATC750	.750	1"	.500	3.40	.440	1.215			\$730.00
SATC875	.875	1"	.500	3.40	.440	1.434			\$760.00
SATC100	1.00	1"	.500	3.40	.440	1.480			\$840.00
SATC125	1.25	1-1/4"	.500	3.50	.440	2.000			\$999.00

* No keyway



A. B. TOOLS, INC.
 1051 Aviation Blvd.
 Lincoln, CA 95648-9312

Phone 916 408-2442
 FAX 916 993-3949

www.abtoolsinc.com
 E-Mail: mail@abtoolsinc.com