

Reduced Shank Solid Carbide End Mills from .140 to 1.0 diameters with your decimal width in 4-6 working days

Machining what part material, please? _____

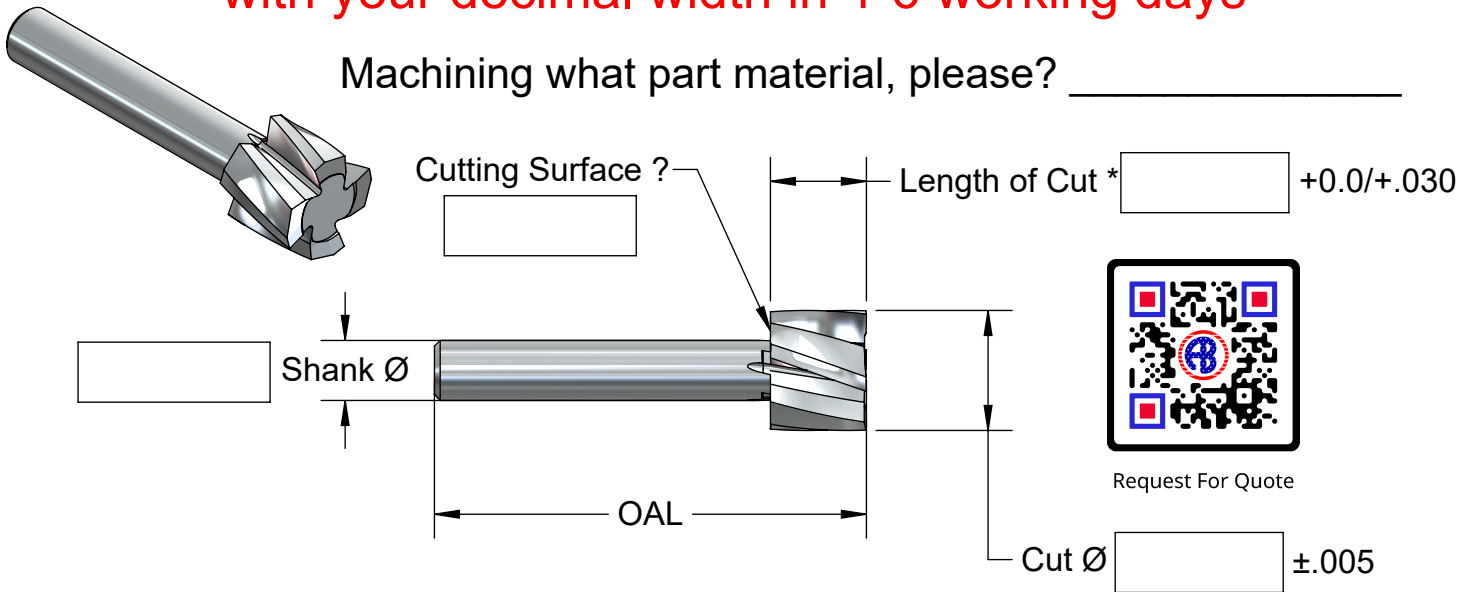

Lollipop Style

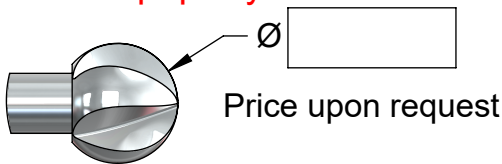

Taper/Chamfer

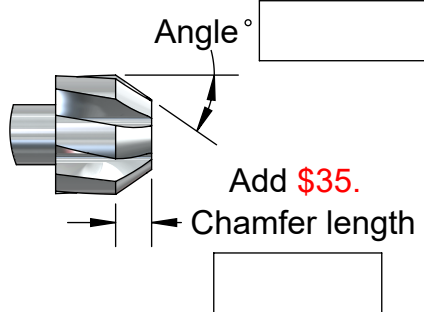

Ballnose Style

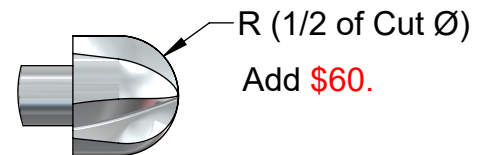

Corner Radius

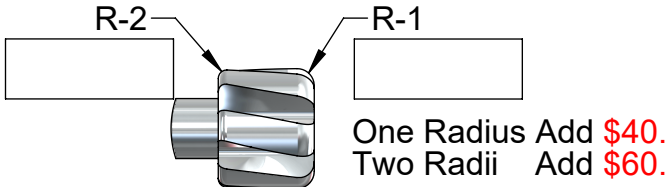

Slot plus Top Chamfers

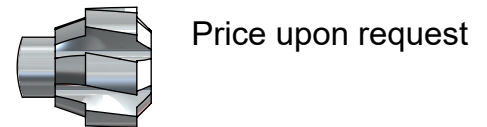

Shank Ø	OAL	Cut Ø	Length of Cut Max	Basic Prices
1/8"	1.5	.140 - .250	.250	\$125.
3/16"	1.5	.195 - .375	.375	\$135.
1/4"	2.0	.260 - .500	.500	\$150.
5/16"	2.25	.320 - .625	.625	\$165.
3/8"	2.5	.390 - .750	.750	\$200.
1/2"	3.0	.515 - 1.0	1.0	\$215.

* If the back surface is cutting the Length of Cut will be held to ±.0005".



A. B. TOOLS, INC.
1051 Aviation Blvd.
Lincoln, CA 95648-9312

Phone 916 408-2442
FAX 916 993-3949

www.abtoolsinc.com
E-Mail: mail@abtoolsinc.com