

Picatinny/NATO Rail Cutters

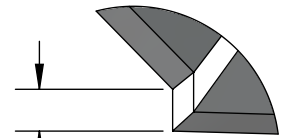

Request For Quote

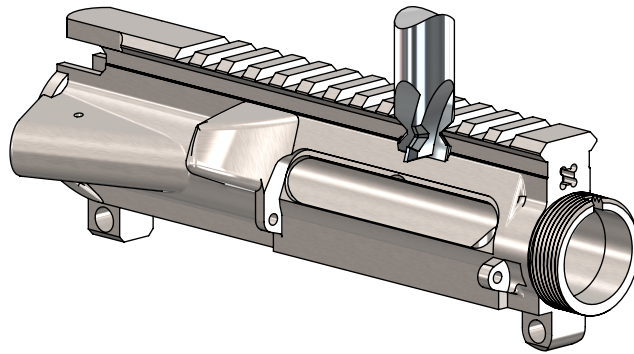

Step

DETAIL A
SCALE 10 : 1

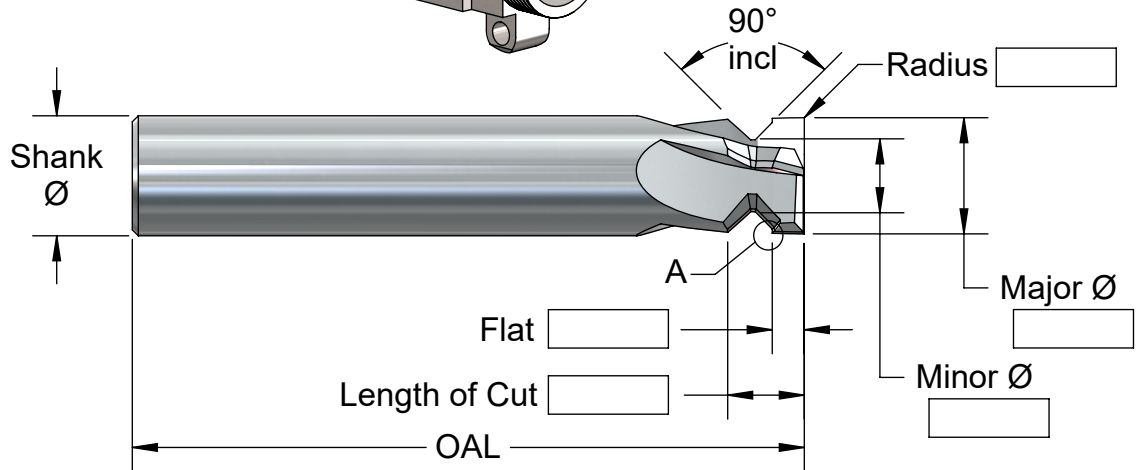
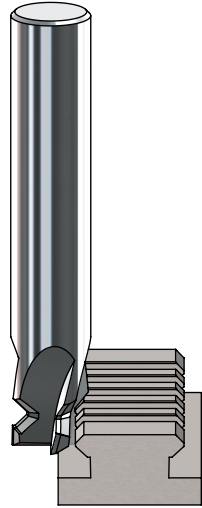

Number	Major Ø	Minor Ø	Length of Cut	Flat	Radius	Shank Ø	OAL	No. of Flutes	Price
PT605-90H-3	.605	.385	.399	.167	None	5/8"	3.5	3	\$150.
PT605-90H-4	.605	.385	.399	.167	None	5/8"	3.5	4	\$160.
PT480-90H-2	.480	.260	.399	.167	None	1/2"	2.5	2	\$135.
PT480-90H-3	.480	.260	.399	.167	None	1/2"	2.5	3	\$143.
PTN625-90H-3*	.625	.405	.387	.143	.039	5/8"	3.5	3	\$163.
PTN625-90H-4*	.625	.405	.387	.143	.039	5/8"	3.5	4	\$170.
PTN500-90H-2*	.500	.280	.387	.143	.039	1/2"	2.5	2	\$140.
PTN500-90H-3*	.500	.280	.387	.143	.039	1/2"	2.5	3	\$148.

* Cutter produces NATO rail

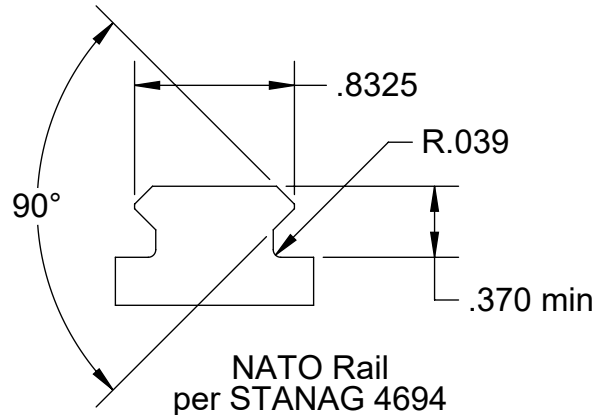
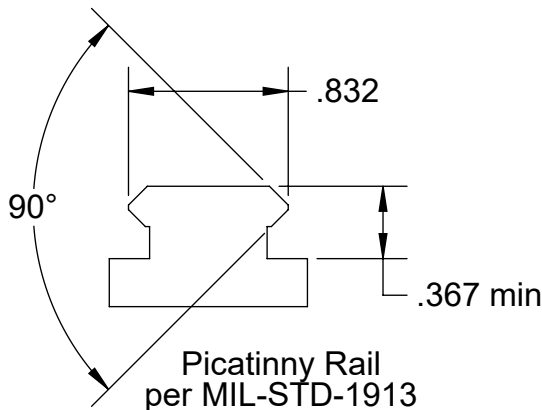

A. B. TOOLS, INC.
1051 Aviation Blvd.
Lincoln, CA 95648-9312

Phone 916 408-2442
FAX 916 993-3949

www.abtoolsinc.com
E-Mail: mail@abtoolsinc.com