

Solid Carbide O-Ring Dovetails for Lathes

Single flute carbide O-Ring form tools for lathe applications that match Parker-Hannifin standards

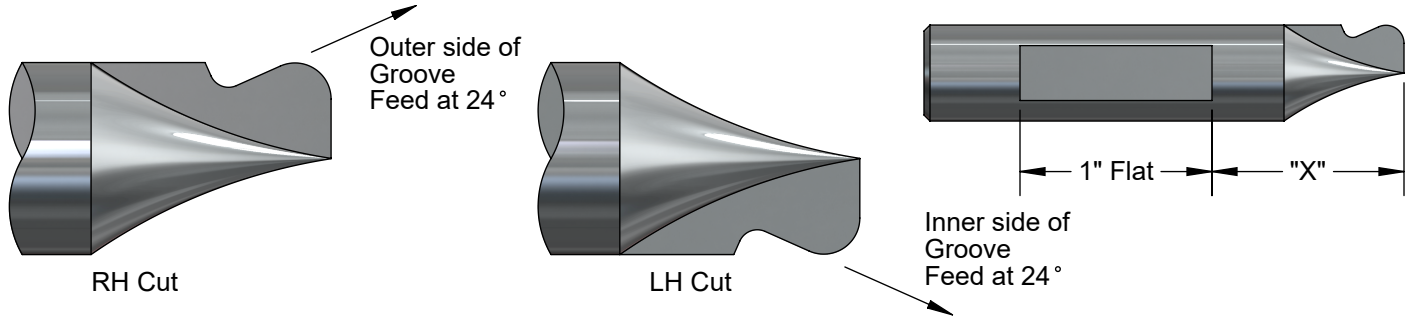

NUMBER		O'RING Ø	*NECK Ø	SLOT DEPTH	TOP RAD.	BOTT. RAD.	X	SHANK Ø & OAL	PRICES	
RH Cut	LH Cut								No Coat	AITiN
DTL1/16-R	DTL1/16-L	.070	.057	.051	.005	.015	1/2"	3/16" X 2.0	\$85.	\$89.
DTL1/16-054-R	DTL1/16-054-L	.070	.059	.054	.005	.016	1/2"	3/16" X 2.0	\$85.	\$89.
DTL3/32-R	DTL3/32-L	.103	.085	.082	.010	.015	1/2"	3/16" X 2.0	\$85.	\$89.
DTL1/8-R	DTL1/8-L	.139	.115	.112	.010	.031	5/8"	1/4" X 2.0	\$95.	\$99.
DTL3/16-R	DTL3/16-L	.210	.173	.172	.015	.031	3/4"	5/16" X 2.5	\$105.	\$112.
DTL1/4-R	DTL1/4-L	.275	.233	.232	.015	.062	7/8"	3/8" X 2.5	\$120.	\$127.
DTL3/8-R	DTL3/8-L	.375	.317	.317	.020	.094	1"	1/2" X 2.5	\$170.	\$179.

Specials in 4-6 working days

Machining what part material, please? _____

Low Carbon Steel: 500 SFM, .0005-.0010 IPR
 Aluminum: 6000 SFM, .0005-.0010 IPR
 304 SS: 225 SFM, .0005-.0010 IPR



Request For Quote

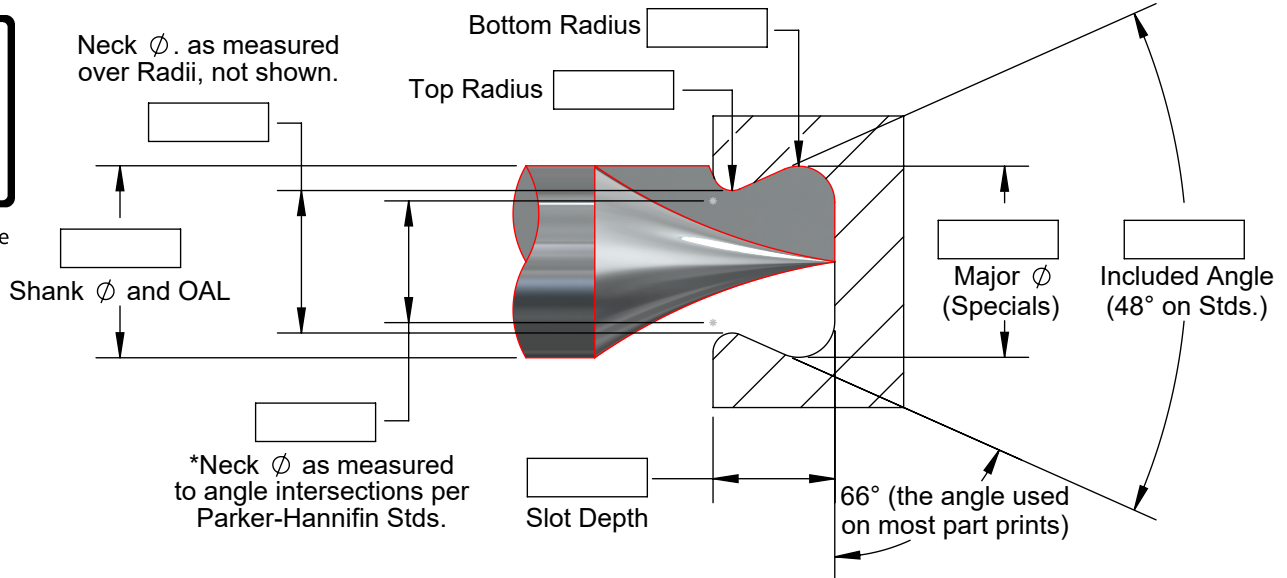

Special Carbide Cutters for O-Ring Grooves	To 1/4 Major Ø	1 at \$185. and 2 at \$160. each
	.251 thru .375 Major Ø	1 at \$220. and 2 at \$175. each
	.376 thru .500 Major Ø	1 at \$260. and 2 at \$190. each



A. B. TOOLS, INC.
 1051 Aviation Blvd.
 Lincoln, CA 95648-9312

Phone 916 408-2442
 FAX 916 993-3949

www.abtoolsinc.com
 E-Mail: mail@abtoolsinc.com