

# Solid Carbide Dovetail Cutters for Half Dovetail O-Ring Grooves

NUMBER	O-RING SIZE	PART Ø TSC	NECK Ø OVER R	SLOT DEPTH	TOP RAD.	BOTTOM RAD.	NO. OF FLUTES	PRICE	AITIN
HDG1/16	.070	.065	.0545	.054	.005	.015	2	\$70.	\$74.
HDG3/32	.103	.096	.0775	.084	.010	.015	2	\$70.	\$74.
HDG1/8	.139	.126	.103	.114	.010	.031	2	\$80.	\$84.
HDG3/16	.210	.1915	.146	.1745	.015	.031	2	\$90.	\$97.
HDG1/4	.275	.256	.2005	.236	.015	.062	3	\$110.	\$117.
HDG3/8	.375	.354	.283	.321	.020	.093	4	\$140.	\$149.

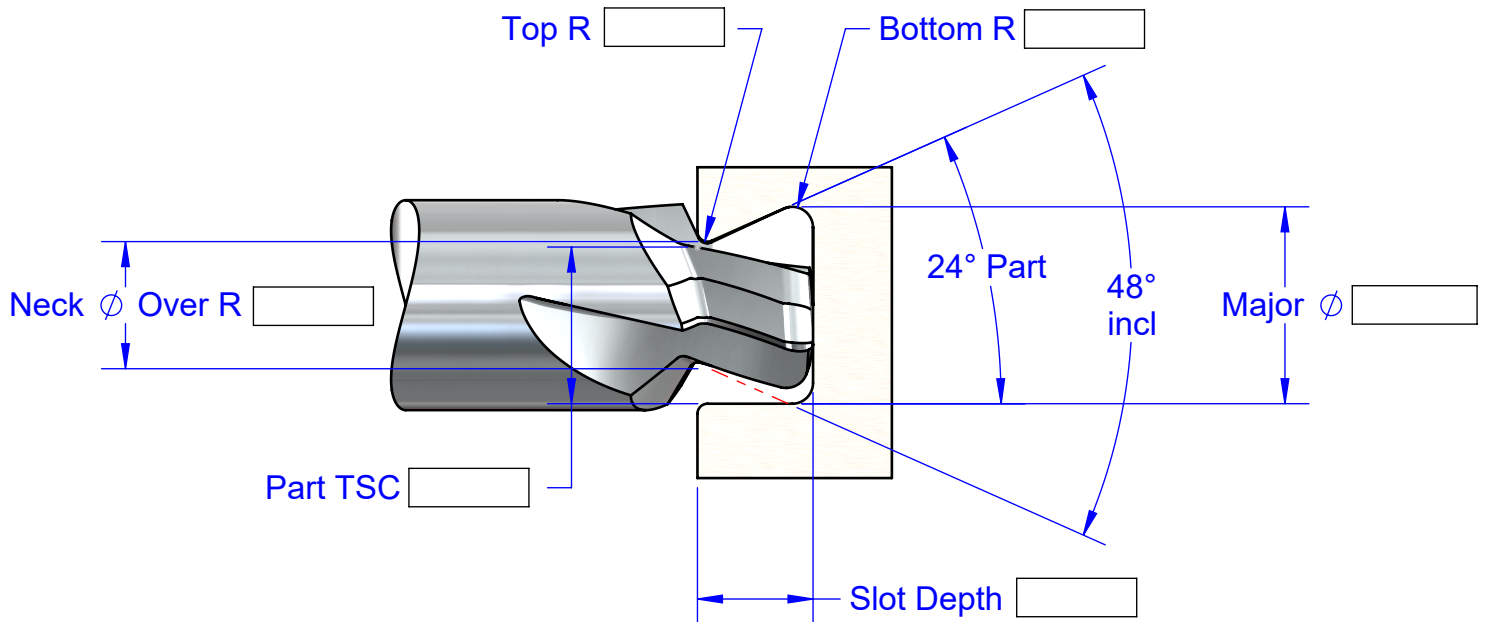

Reference Chart

NUMBER	MAJOR Ø	SHANK Ø	OAL
HDG1/16	.081	3/16"	2.0
HDG3/32	.125	3/16"	2.0
HDG1/8	.160	3/16"	2.0
HDG3/16	.253	5/16"	2.5
HDG1/4	.328	3/8"	2.5
HDG3/8	.447	1/2"	2.5

Specials in 4-6  
Working Days



Request For Quote



A. B. TOOLS, INC.  
1051 Aviation Blvd.  
Lincoln, CA 95648-9312

Phone 916 408-2442  
FAX 916 993-3949

www.abtoolsinc.com  
E-Mail: mail@abtoolsinc.com