

NEW!!! Carbide Tipped Corner Rounders NEW!!!

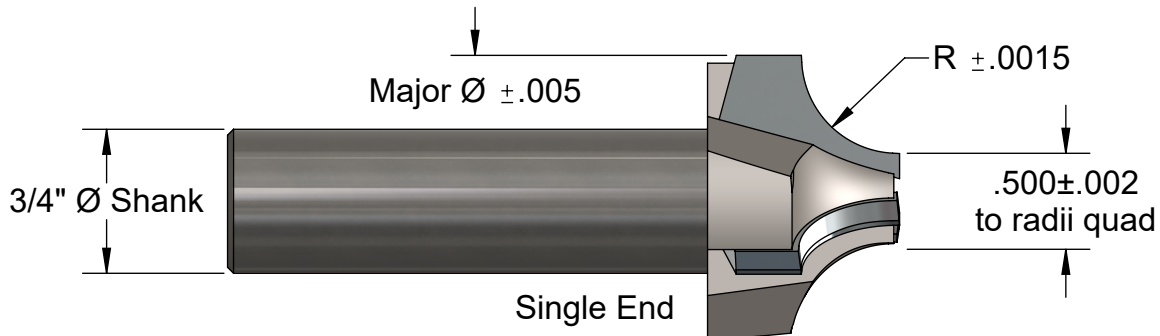

Request For Quote

Special Carbide Tipped Corner Rounders in 4-6 working days

Machining what part material, please? _____

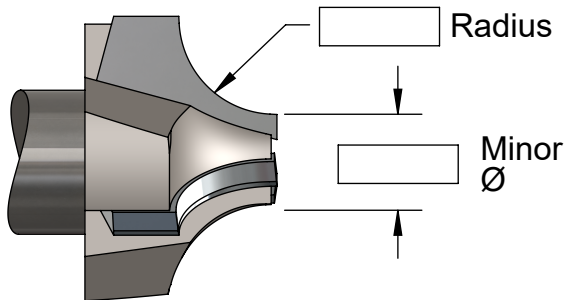

All AB Tools corner rounders are made with these features to avoid gouging.

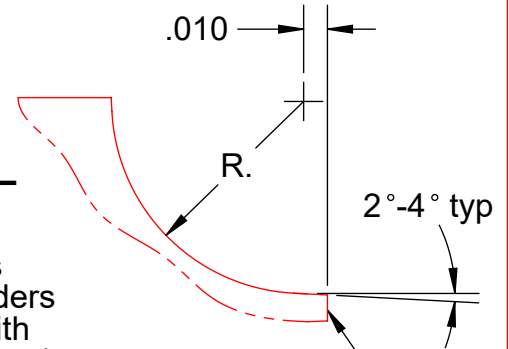

End Cutting, also the major Ø is cutting for 1/8 min.

Tool No.	Rad.	Major Ø	OAL	Price	
				No-Coat	AlTiN
3 Flutes, Positive Rake					
CR3-187	.187	.895	3.25	\$215.	\$236.
CR3-203	.203	.926		\$225.	\$246.
CR3-218	.218	.956		\$240.	\$261.
CR3-250	.250	1.020		\$245.	\$269.
CR3-281	.281	1.082		\$265.	\$289.
CR3-312	.312	1.144		\$275.	\$299.
CR3-343	.343	1.206		\$300.	\$324.
CR3-375	.375	1.270		\$325.	\$351.
CR3-406	.406	1.332		\$345.	\$371.
CR3-437	.437	1.394		\$355.	\$381.
CR3-468	.468	1.456		\$370.	\$396.
CR3-500	.500	1.520		\$390.	\$422.
CR3-562	.562	1.644	3.50	\$430.	\$462.
CR3-625	.625	1.770		\$475.	\$576.

Tool No.	Rad.	Rad. Inch	Major Ø	OAL	Price	
					No-Coat	AlTiN
3 Flutes, Positive Rake						
CR3-5	5 mm	.197	.914	3.25	\$225.	\$246.
CR3-6	6 mm	.236	.992		\$245.	\$269.
CR3-8	8 mm	.315	1.150		\$300.	\$324.
CR3-10	10 mm	.394	1.307		\$345.	\$371.
CR3-12	12 mm	.472	1.465		\$390.	\$422.
CR3-16	16 mm	.630	1.780		3.50	\$475.



A. B. TOOLS, INC.
1051 Aviation Blvd.
Lincoln, CA 95648-9312

Phone 916 408-2442
FAX 916 993-3949

www.abtoolsinc.com
E-Mail: mail@abtoolsinc.com