

Solid Carbide Dovetail Cutters from .750 to 1.5 diameters

Custom Specials upon request.

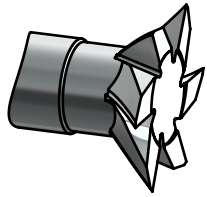

Machining what part material, please? _____

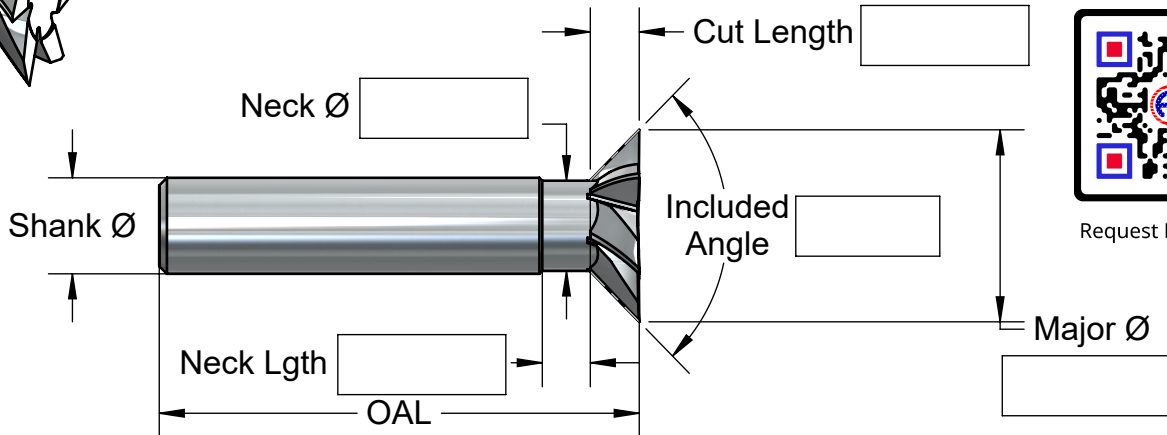

.002-.005 flat on all ODs

Add \$40. each for corner radius (R.060 Max)

1/2" shank Ø x 2.5 OAL

Number	Major Ø	Incl. Angle	Cut Length	Neck Ø	Neck Lgth	Flutes	Price	Altin
SCD75-60	.750	60°	.313	.370	.250	6	\$240.	\$251.
SCD75-90	.750	90°	.188	.360	.250	6	\$240.	\$251.
SCD75-120	.750	120°	.120	.320	.370	6	\$240.	\$251.
SCD1-60	1.0	60°	.435	.480	.250	6	\$255.	\$271.
SCD1-90	1.0	90°	.255	.470	.250	6	\$255.	\$271.
SCD1-120	1.0	120°	.160	.430	.370	6	\$255.	\$271.

5/8" shank Ø x 3.0 OAL

SCD125-60	1.25	60°	.500	.600	.250	7	\$320.	\$340.
SCD125-90	1.25	90°	.360	.515	.250	7	\$320.	\$340.
SCD125-120	1.25	120°	.225	.450	.370	7	\$320.	\$340.

3/4" shank Ø x 3.5 OAL

SCD15-60	1.5	60°	.625	.725	.250	7	\$385.	\$410.
SCD15-90	1.5	90°	.440	.600	.250	7	\$385.	\$410.
SCD15-120	1.5	120°	.285	.500	.370	7	\$385.	\$410.



A. B. TOOLS, INC.
1051 Aviation Blvd.
Lincoln, CA 95648-9312

Phone 916 408-2442
FAX 916 993-3949

www.abtoolsinc.com
E-Mail: mail@abtoolsinc.com