

Carbide Tipped Dovetail Cutters

Specials in 4-6 Working Days

Machining what part material, please? _____

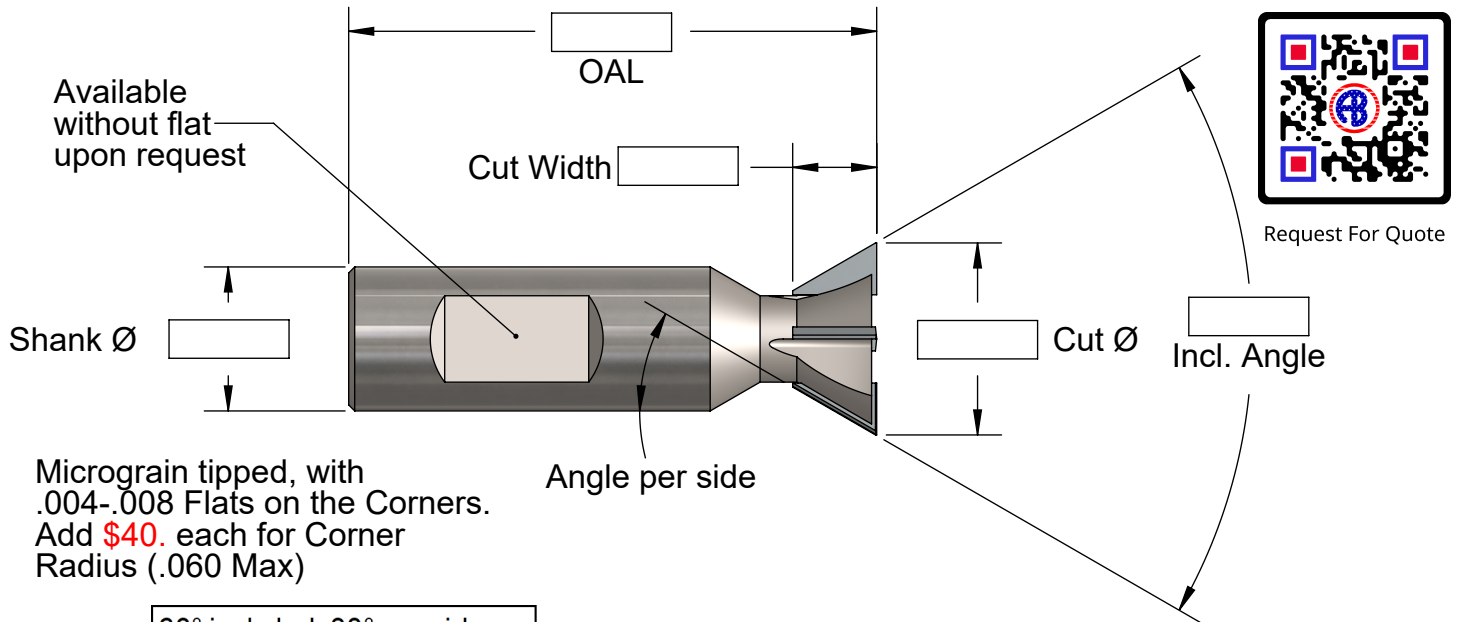

Micrograin tipped, with .004-.008 Flats on the Corners.
Add \$40. each for Corner Radius (.060 Max)

60° included; 30° per side								
Number	Incl. Angle	Cut Ø	Cut Width	Shank Ø	OAL	Flutes	Price	
							No-Coat	AlTiN
D60-.75	60°	.750	.313	3/4"	2.75	3	\$190.	\$202.
D60-1.0	60°	1.00	.438	3/4"	2.75	4	\$200.	\$217.
D60-1.25	60°	1.25	.500	3/4"	3.0	5	\$210.	\$231.
D60-1.38	60°	1.38	.500	3/4"	3.0	6	\$220.	\$244.
D60-1.5	60°	1.50	.625	3/4"	3.5	6	\$280.	\$304.
D60-2.0	60°	2.00	.875	1"	3.75	8	\$325.	\$426.
D60-2.5	60°	2.50	.875	1"	3.75	8	\$420.	\$537.

90° included; 45° per side								
Number	Incl. Angle	Cut Ø	Cut Width	Shank Ø	OAL	Flutes	Price	
							No-Coat	AlTiN
D90-.75	90°	.750	.188	1/2"	2.25	3	\$195.	\$207.
D90-1.0	90°	1.00	.250	1/2"	2.5	5	\$205.	\$222.
D90-1.25	90°	1.25	.313	5/8"	2.75	5	\$265.	\$286.
D90-1.5	90°	1.50	.438	3/4"	3.25	6	\$345.	\$371.
D90-1.75	90°	1.75	.500	3/4"	3.75	6	\$395.	\$427.
D90-2.0	90°	2.00	.563	1"	4.0	6	\$440.	\$541.
D90-2.5	90°	2.50	.750	1"	4.5	6	\$510.	\$627.



A. B. TOOLS, INC.
1051 Aviation Blvd.
Lincoln, CA 95648-9312

Phone 916 408-2442
FAX 916 993-3949

www.abtoolsinc.com
E-Mail: mail@abtoolsinc.com