

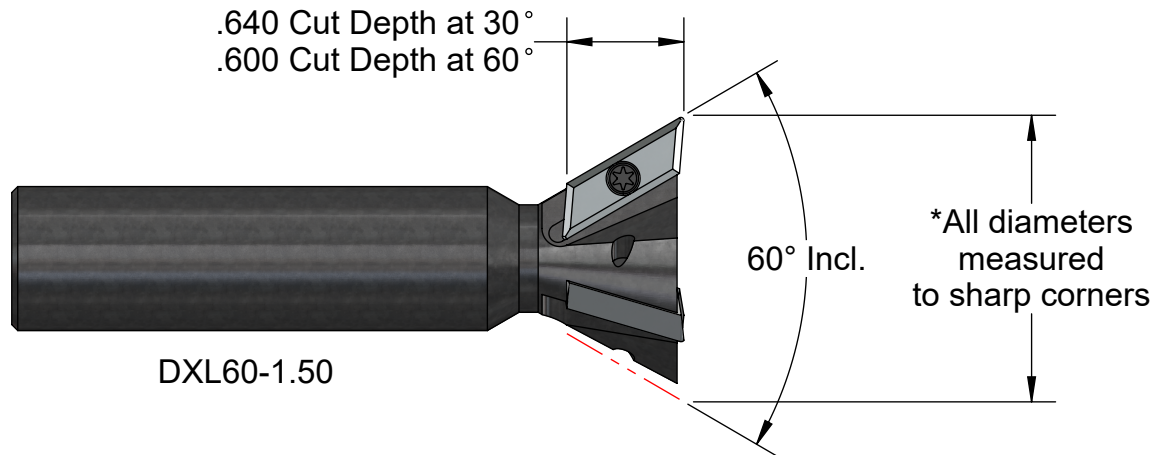



The Dexi-Dovetail Long Inserts



Number	*Cut Ø	Cut Depth	Incl. Angle	Shank Ø & Overall	Flutes	Price
DXL20-1.25	1.25	.650	20°	3/4" X 3.5	3	\$295.
DXL30-1.25	1.25	.640	30°	3/4" X 3.5	3	\$295.
DXL30-1.312	1.313	.640	30°	3/4" X 3.5	3	\$300.
DXL30-1.37	1.375	.640	30°	3/4" X 3.5	3	\$305.
DXL30-2.0	2.0	.640	30°	1" X 3.88	5	\$455.
DXL40-1.50	1.5	.630	40°	3/4" X 3.5	3	\$315.
DXL50-1.50	1.5	.620	50°	3/4" X 3.5	3	\$315.
DXL50-2.0	2.0	.620	50°	1" X 4.0	4	\$435.
DXL60-1.50	1.5	.600	60°	3/4" X 3.5	3	\$315.
DXL60-1.62	1.625	.600	60°	3/4" X 3.5	3	\$330.
DXL60-2.0	2.0	.600	60°	1" X 3.88	4	\$455.
DXL60-3.0	3.0	.600	60°	1-1/4" X 4.5	6	\$665.

Long Insert 	Insert Number	Radius	Price	
			No-Coat	AlTiN
	Di60L-1	.015		
	Di60L-2	.030	\$19.	\$24.
	Di60L-3	.046		

Screw & Key	Number	Price
	DX-3MM	\$2.50
	T9	\$7.50

Insert screw torque to 18-20 in lbs.

We use all these cutters in production, milling (38Rc) 4340 at 1100 to 1800 RPM and .001 to .002 IPT.



A. B. TOOLS, INC.
1051 Aviation Blvd.
Lincoln, CA 95648-9312

Phone 916 408-2442
FAX 916 993-3949

www.abtoolsinc.com
E-Mail: mail@abtoolsinc.com