

The Dexi-Dovetail Short Inserts

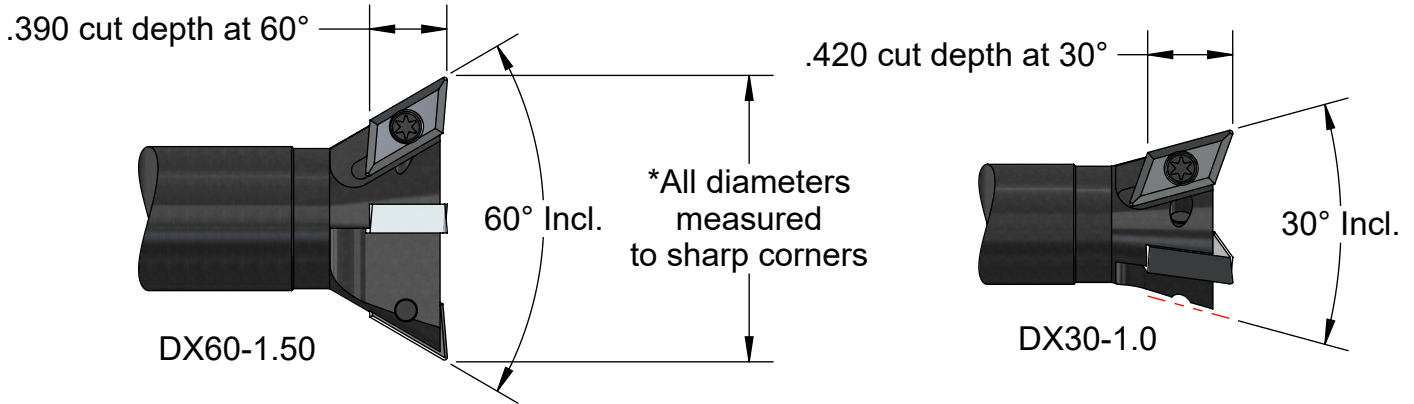

Cutter Number	*Cut Ø	Cut Depth	Incl. Angle	Shank Ø & Overall	Flutes	Price
DX10-1.25	1.25	.440	10°	3/4" X 3.5	4	\$260.
DX20-1.0	1.0	.430	20°	5/8" X 3.5	3	\$230.
DX20-1.25	1.25	.430	20°	3/4" X 3.5	3	\$250.
DX20-1.50	1.5	.430	20°	3/4" X 3.5	4	\$275.
DX30-1.0	1.0	.420	30°	5/8" X 3.5	3	\$250.
DX30-1.25	1.25	.420	30°	3/4" X 3.5	3	\$250.
DX40-1.25	1.25	.410	40°	3/4" X 3.5	3	\$250.
DX45-1.25	1.25	.405	45°	3/4" X 3.5	3	\$250.
DX50-1.25	1.25	.400	50°	3/4" X 3.5	3	\$250.
DX60-1.25	1.25	.390	60°	1/2" X 3.0	3	\$250.
DX60-1.38	1.375	.390	60°	5/8" X 3.5	3	\$260.
DX60-1.50	1.5	.390	60°	3/4" X 3.5	4	\$290.
DX60-8	1.25	.390	60°	1-1/4" X 8.0	3	\$345.

Short Insert	Insert Number	Radius	Price	
			No-Coat	AlTiN
	Di60-0078	.0078		
	Di60-1	.015	\$17.	\$20.
	Di60-2	.030		

Screw & Key	Number	Price
	DX-3MM	\$2.50
	T9	\$7.50

Insert screw torque to 18-20 in lbs.

We use all these cutters in production, milling (38Rc) 4340 at 1100 to 1800 RPM and .001 to .002 IPT.



A. B. TOOLS, INC.
1051 Aviation Blvd.
Lincoln, CA 95648-9312

Phone 916 408-2442
FAX 916 993-3949

www.abtoolsinc.com
E-Mail: mail@abtoolsinc.com