

Carbide Tipped Corner Rounders

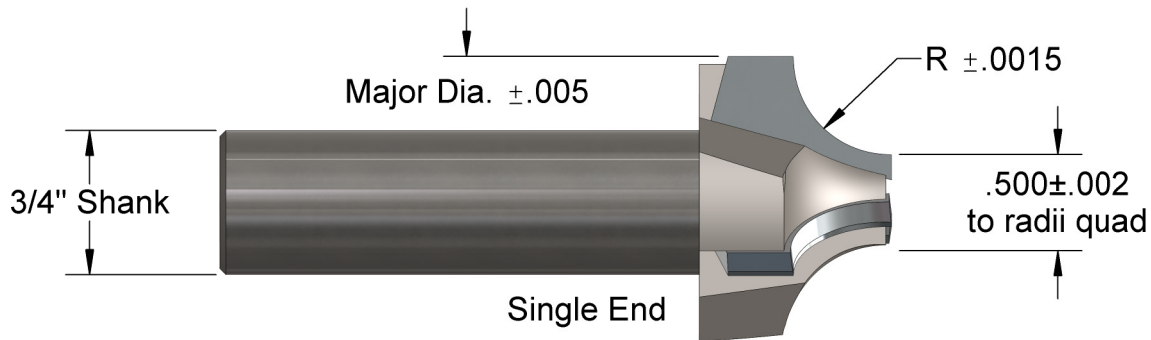

Special Carbide Tipped Corner Rounders in 4-6 working days

Machining what part material, please? _____

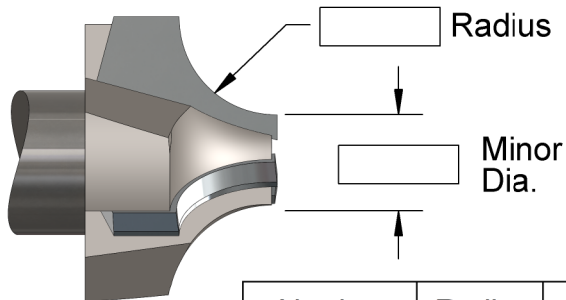

All AB Tools corner rounders are made with these features to avoid gouging.

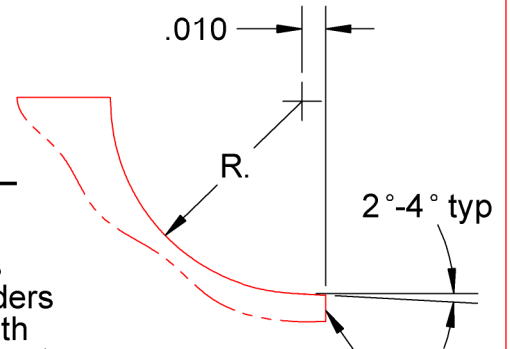

End Cutting, also the major Dia. is cutting for 1/8 min.

Number	Radius	Major Dia.	OAL	Price	
				No-Coat	AlTiN
3 Flutes, Positive Rake					
CR3-187	.187	.895	3.25	\$205.	\$226.
CR3-203	.203	.926		\$215.	\$236.
CR3-218	.218	.956		\$230.	\$251.
CR3-250	.250	1.020		\$235.	\$259.
CR3-281	.281	1.082		\$250.	\$274.
CR3-312	.312	1.144		\$260.	\$284.
CR3-343	.343	1.206		\$285.	\$309.
CR3-375	.375	1.270		\$310.	\$336.
CR3-406	.406	1.332		\$325.	\$351.
CR3-437	.437	1.394		\$335.	\$361.
CR3-468	.468	1.456		\$350.	\$376.
CR3-500	.500	1.520	\$370.	\$402.	
CR3-562	.562	1.644	3.50	\$400.	\$432.
CR3-625	.625	1.770		\$445.	\$546.



A. B. TOOLS, INC.
1051 Aviation Blvd.
Lincoln, CA 95648-9312

Phone 916 408-2442
FAX 916 993-3949

www.abtoolsinc.com
E-Mail: mail@abtoolsinc.com