

Solid Carbide Taper End Mills

(3) Flutes

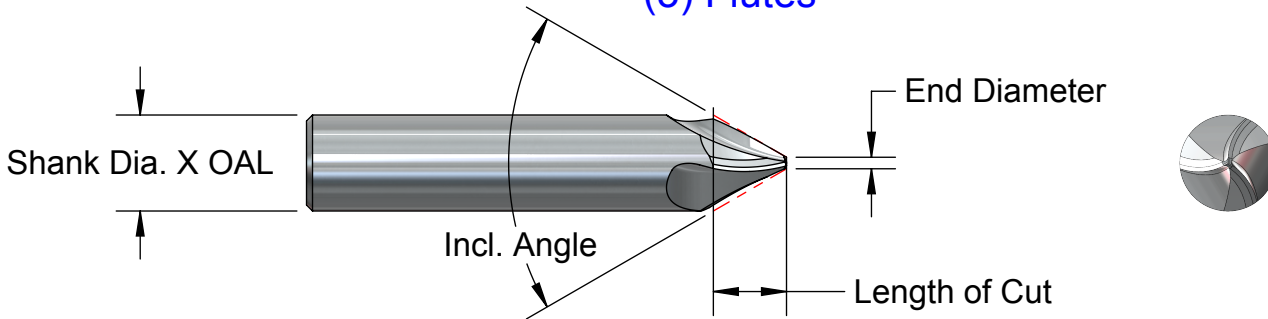

Specials in 4-6 Working Days

Number	End Dia.	Incl. Angle	Length of Cut	Shank X OAL
TEM060-10	.060	10°	.729	3/16 X 2.5
TEM060-12	.060	12°	.607	3/16 X 2.5
TEM060-15	.060	15°	.484	3/16 X 2.5
TEM060-20	.060	20°	.893	3/8 X 2.5
TEM060-25	.060	25°	.710	3/8 X 2.5
TEM060-30	.060	30°	.588	3/8 X 2.5
TEM060-35	.060	35°	.500	3/8 X 2.5
TEM060-40	.060	40°	.604	1/2 X 2.5
TEM060-45	.060	45°	.531	1/2 X 2.5
TEM060-50	.060	50°	.472	1/2 X 2.5
TEM060-60	.060	60°	.381	1/2 X 2.5

Shank X OAL	Price	
	No-Coat	AlTiN
3/16 X 2.5	\$75.	\$79.
1/4 X 2.5	\$75.	\$80.
3/8 X 2.5	\$85.	\$92.
1/2 X 2.5	\$92.	\$101.
1/2 X 3	\$95.	\$104.
1/2 X 4	\$105.	\$116.

Number	End Dia.	Incl. Angle	Length of Cut	Shank X OAL
TEM120-10	.120	10°	.743	1/4 X 2.5
TEM120-12	.120	12°	.618	1/4 X 2.5
TEM120-15	.120	15°	.494	1/4 X 2.5
TEM120-20	.120	20°	.723	3/8 X 2.5
TEM120-25	.120	25°	.575	3/8 X 2.5
TEM120-30	.120	30°	.476	3/8 X 2.5
TEM120-35	.120	35°	.404	3/8 X 2.5
TEM120-40	.120	40°	.522	1/2 X 2.5
TEM120-45	.120	45°	.459	1/2 X 2.5
TEM120-50	.120	50°	.407	1/2 X 2.5
TEM120-60	.120	60°	.329	1/2 X 2.5

Number	End Dia.	Incl. Angle	Length of Cut	Shank X OAL
TEM180-10	.180	10°	1.829	1/2 X 4
TEM180-12	.180	12°	1.522	1/2 X 4
TEM180-15	.180	15°	1.215	1/2 X 3
TEM180-20	.180	20°	.907	1/2 X 3
TEM180-25	.180	25°	.722	1/2 X 3
TEM180-30	.180	30°	.597	1/2 X 3
TEM180-35	.180	35°	.507	1/2 X 2.5
TEM180-40	.180	40°	.440	1/2 X 2.5
TEM180-45	.180	45°	.386	1/2 X 2.5
TEM180-50	.180	50°	.343	1/2 X 2.5
TEM180-60	.180	60°	.277	1/2 X 2.5

Phone 916 408-2442 FAX 916 408-0740

Toll free phone 866 440-8665



A. B. TOOLS, INC.
1051 Aviation Blvd.
Lincoln, CA, 95648-9312

If any product is not satisfactory
we will modify, replace or refund.

www.abtoolsinc.com
E-Mail: mail@abtoolsinc.com