

Bevel Cutters, Solid Carbide, In Stock.

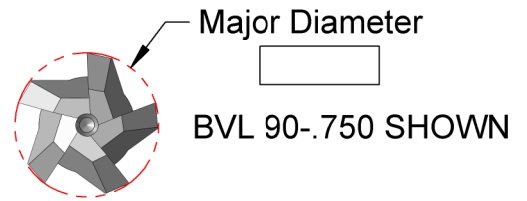
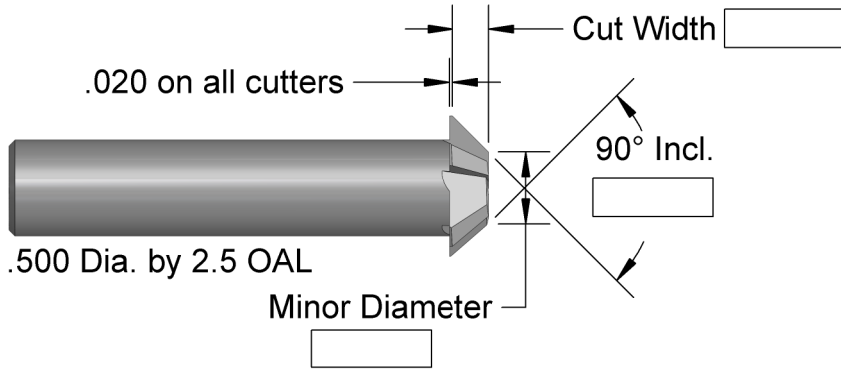

90° Included Angles

Number	Major Diameter	Minor Diameter	Cut Width	Number of Flutes	Price
BVL 90-.500	.500	.250	.125	4	\$110.
BVL 90-.750	.750	.375	.188	5	\$135.
BVL 90-1.00	1.000	.375	.312	6	\$165.
BVL 90-1.25	1.250	.500	.375	8	\$195.
BVL 90-1.50*	1.500	.500	.500	10	\$235.

Specials in 4-6 Working Days

60° Included Angles

Number	Major Diameter	Minor Diameter	Cut Width	Number of Flutes	Price
BVL 60-.500	.500	.246	.220	4	\$110.
BVL 60-.750	.750	.390	.312	5	\$135.
BVL 60-1.00	1.000	.503	.430	6	\$165.
BVL 60-1.25*	1.250	.673	.500	8	\$195.
BVL 60-1.50*	1.500	.778	.625	10	\$235.

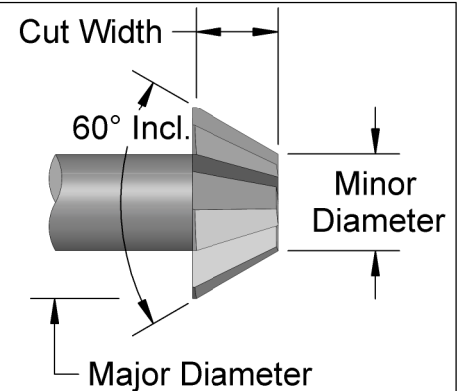

120° Included Angles

Number	Major Diameter	Minor Diameter	Cut Width	Number of Flutes	Price
BVL 120-.500	.500	.188	.090	4	\$110.
BVL 120-.750	.750	.317	.125	5	\$135.
BVL 120-1.00	1.000	.350	.188	6	\$165.
BVL 120-1.25	1.250	.488	.220	8	\$195.
BVL 120-1.50	1.500	.634	.250	10	\$235.

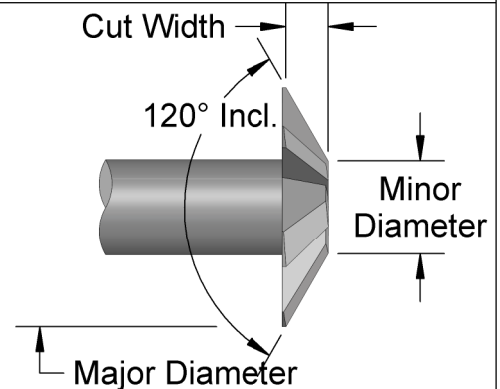

* These cutters are on 3/4" shanks and 2-3/4" OAL



A. B. TOOLS, INC.
1051 Aviation Blvd.
Lincoln, CA 95648-9312

Phone 916 408-2442
FAX 916 993-3949

www.abtoolsinc.com
E-Mail: mail@abtoolsinc.com