

SAW ARBORS for Carbide or HSS Saws with key drives for 5/8 and larger arbors

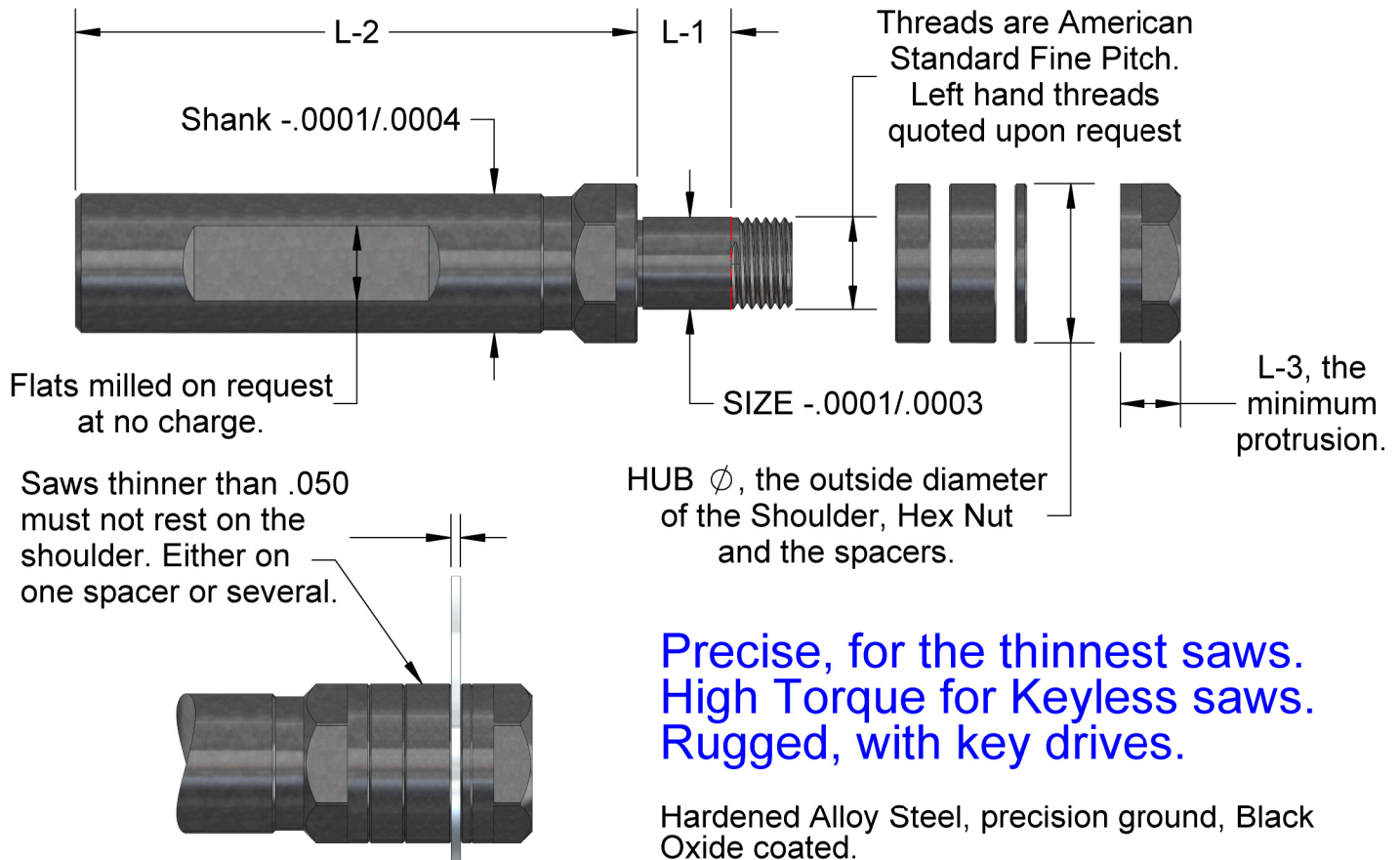

Shim Style spacers in sets from .001 thru .015 are available from your Industrial Distributor.

The spacer assortments will accommodate most saws and spacers that will fit in the L-1 Length.
*Spacers ordered with Keyed Arbors will also have keyways.

Number	Size	Shank	L-1	L-2	L-3	Hub	Spacers with each Arbor	Price
SA250	.250	.500	.350	2.13	.250	.570	.0625 .125 .1875	\$225.
SA375	.375	.625	.375	2.40	.280	.710		\$245.
SA500	.500	.750	.500	3.00	.325	.855		\$265.
SA625	.625	.875	.500	3.15	.390	1.000	.0625 .1875 .250	\$330.
SA750	.750	1.00	.500	3.40	.440	1.215		\$345.
SA875	.875	1.00	.500	3.40	.440	1.434		\$360.
SA100	1.00	1.00	.500	3.50	.440	1.480		\$400.
SA125	1.25	1.25	.500	3.50	.440	2.000		\$475.

*Sorry, unable to manufacture precise spacers thinner than .0625 in steel; suggest Robb-Jack's Solid Carbide spacers for thinner sizes.



A. B. TOOLS, INC.
1051 Aviation Blvd.
Lincoln, CA 95648-9312

Phone 916 408-2442
FAX 916 993-3949

www.abtoolsinc.com
E-Mail: mail@abtoolsinc.com