

# Carbide Tipped Dovetail Cutters

## Specials in 4-6 Working Days

Machining what part material, please? \_\_\_\_\_

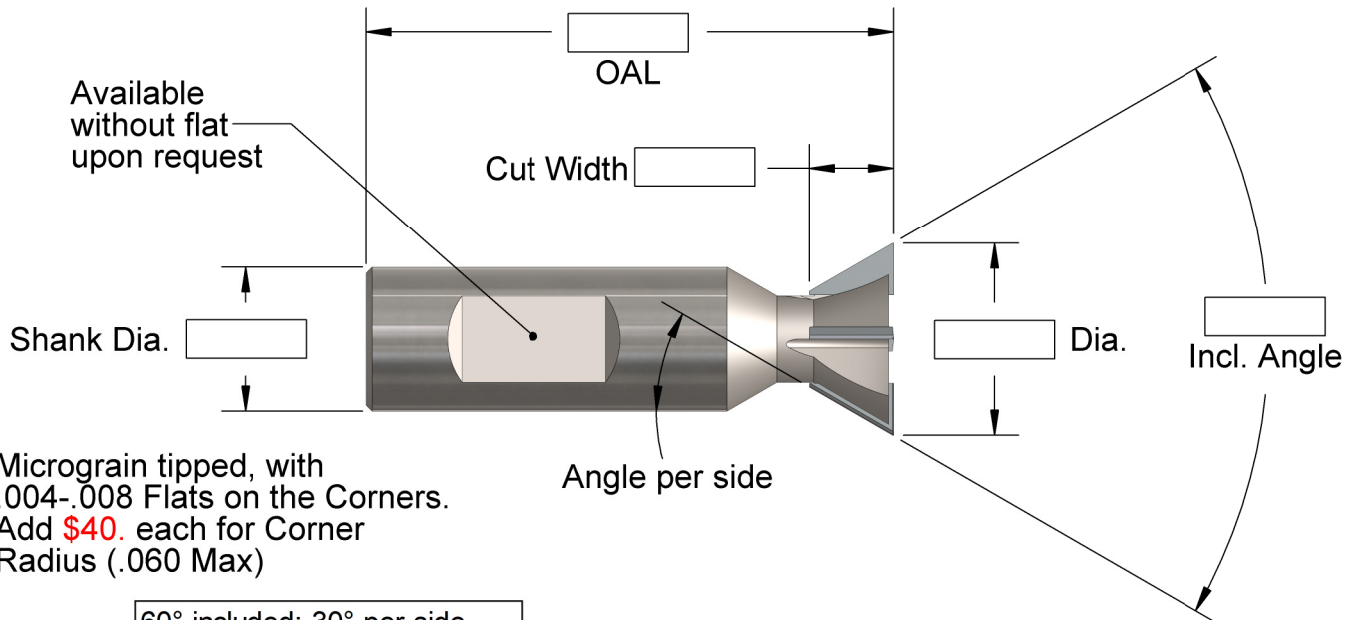

Micrograin tipped, with .004-.008 Flats on the Corners.  
 Add \$40. each for Corner Radius (.060 Max)

| 60° included; 30° per side |             |      |           |            |       |   |         |        |
|----------------------------|-------------|------|-----------|------------|-------|---|---------|--------|
| Number                     | Incl. Angle | Dia. | Cut Width | Shank Dia. | OAL   | N | Price   |        |
|                            |             |      |           |            |       |   | No-Coat | AlTiN  |
| D60-.75                    | 60°         | 3/4  | 5/16      | 3/4        | 2-3/4 | 3 | \$180.  | \$192. |
| D60-1.0                    | 60°         | 1.00 | 7/16      | 3/4        | 2-3/4 | 4 | \$190.  | \$207. |
| D60-1.25                   | 60°         | 1.25 | 1/2       | 3/4        | 3     | 5 | \$200.  | \$221. |
| D60-1.38                   | 60°         | 1.38 | 1/2       | 3/4        | 3     | 6 | \$210.  | \$234. |
| D60-1.5                    | 60°         | 1.50 | 5/8       | 3/4        | 3-1/2 | 6 | \$265.  | \$289. |
| D60-2.0                    | 60°         | 2.00 | 7/8       | 1.0        | 3-3/4 | 8 | \$305.  | \$406. |
| D60-2.5                    | 60°         | 2.50 | 7/8       | 1.0        | 3-3/4 | 8 | \$395.  | \$512. |

| 90° included; 45° per side |             |      |           |            |       |   |         |        |
|----------------------------|-------------|------|-----------|------------|-------|---|---------|--------|
| Number                     | Incl. Angle | Dia. | Cut Width | Shank Dia. | OAL   | N | Price   |        |
|                            |             |      |           |            |       |   | No-Coat | AlTiN  |
| D90-.75                    | 90°         | 3/4  | 3/16      | 1/2        | 2-1/4 | 3 | \$185.  | \$197. |
| D90-1.0                    | 90°         | 1.00 | 1/4       | 1/2        | 2-1/2 | 5 | \$195.  | \$212. |
| D90-1.25                   | 90°         | 1.25 | 5/16      | 5/8        | 2-3/4 | 5 | \$255.  | \$276. |
| D90-1.5                    | 90°         | 1.50 | 7/16      | 3/4        | 3-1/4 | 6 | \$325.  | \$351. |
| D90-1.75                   | 90°         | 1.75 | 1/2       | 3/4        | 3-3/4 | 6 | \$375.  | \$407. |
| D90-2.0                    | 90°         | 2.00 | 9/16      | 1.0        | 4     | 6 | \$410.  | \$511. |
| D90-2.5                    | 90°         | 2.50 | 3/4       | 1.0        | 4-1/2 | 6 | \$475.  | \$592. |

N = number of flutes



A. B. TOOLS, INC.  
 1051 Aviation Blvd.  
 Lincoln, CA 95648-9312

Phone 916 408-2442  
 FAX 916 993-3949

www.abtoolsinc.com  
 E-Mail: mail@abtoolsinc.com